

PAVER BLOCK FIXING INSTRUCTIONS

INTRODUCTION AND ACKNOWLEDGMENTS

This manual is designed as a basic guide to be used by paver laying contractors. The format of the manual and much of the information contained herein are taken from the student manual used by the Interlocking Concrete Pavement Institute (ICPI) in its Basic Level Contractor Certification program.

INTERLOCKING CONCRETE PAVEMENT (ICP)

Interlocking concrete pavements (ICP) are flexible pavements. Flexible pavements are designed to spread loads imposed on a small area of the pavement surface through a base layer (or series of layers or sub-bases) to a large enough area of the soil subgrade that the soil subgrade can support the load without rutting. A 1,000 lb. wheel with a footprint of 40 sq. in. exerts a load on the pavement surface of 3,600 lbs./sq. ft. With proper design and construction, a flexible pavement can expand the footprint to 8 sq. ft. on the soil subgrade, thus reducing the load on the subgrade to only 125 lbs./sq. ft. In a flexible pavement, the pavement surface and base have the ability to move slightly or flex under load then recover when the load is removed.

The unique aspect of interlocking concrete pavements is that the pavers interlock to help spread the imposed loads. There are three kinds of interlock: vertical, rotational and horizontal.

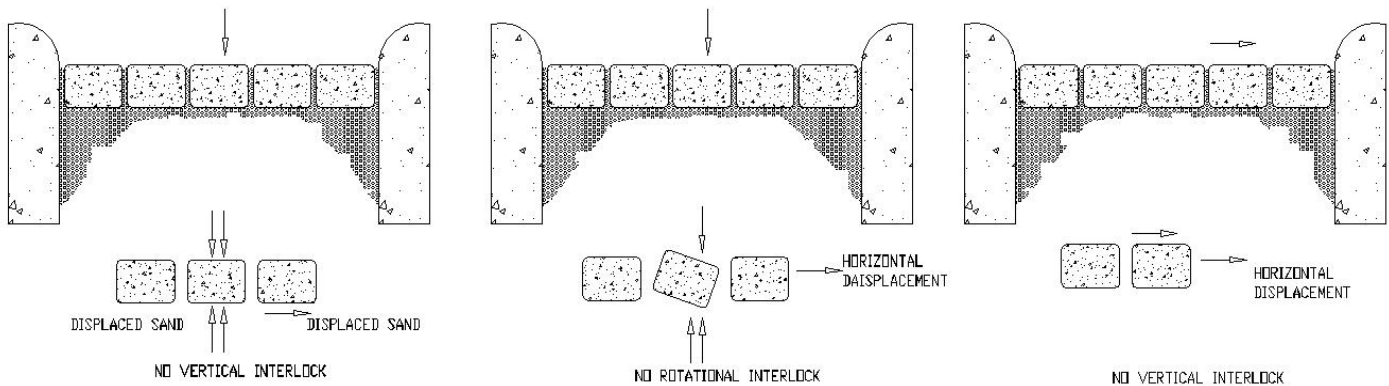

VERTICAL INTERLOCK

This is achieved by the shear transfer of loads to surrounding units through the sand in the joints. This shear transfer also prevents one paver from moving vertically in relationship to its neighbor(s).

ROTATIONAL INTERLOCK

This is achieved through use of the proper paver thickness in relationship to load and use and by a perimeter edge restraint. A slight crown constructed into the pavement will increase rotational interlock and the load bearing capacity of the pavement.

HORIZONTAL INTERLOCK

This is achieved through the use of laying patterns that minimize the length of uninterrupted joint lines and disperse forces from braking, turning and accelerating vehicles. Certain geometrically interlocking paver shapes enhance horizontal interlock.

Herringbone laying patterns are the most effective

The components of an ICP are:

- Subgrade • Geotextile (if needed) • Sub-base (if needed) • Base • Bedding Sand • Edge Restraint
- Interlocking Concrete Pavers • Joint Sand

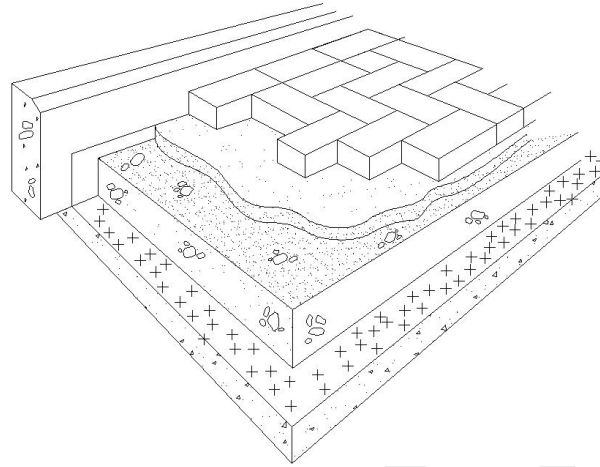

Detailed information on the materials used is contained in Appendix A.

CONSTRUCTING THE ICP

UTILITY LOCATION

Before beginning any phase of the construction process, make sure that all underground utilities, services and structures have been located and clearly marked on the ground surface in all areas involved in the construction process including access lanes. In many areas, a single number such as Miss Utilities may be called.

Items to be located are:

- Electrical • Sanitary sewer • Gas • Septic tank • Water supply
- Telephone • Storm sewer • Cable TV • Drainfield • Irrigation piping

SITE ACCESS

Before any demolition, delivery or construction equipment is allowed on site, make sure that there are no hazardous conditions such as overhead electric lines in the way. Plan all activities so that no damage will occur to existing pavements, structures, trees, shrubbery, gardens or other site amenities.

LAYOUT

Identify the area to be excavated and mark it on the ground with spray paint. Make sure the area to be excavated is at least 12 in. wider on all outside edges than the size of the pavement. Place grade stakes with string lines just outside the area to be excavated, making sure that the excavation is at least 12 in. wider than the edge of pavement. Mark the elevations on the stakes so that the depth of excavation can be checked as it progresses. Use nylon mason's line and set it at the finished elevation of the pavement. Measure all excavations and base thickness from these lines. Set the initial elevations and check them at the beginning of each day with a builders level. The stakes can be moved at night by mischievous persons.

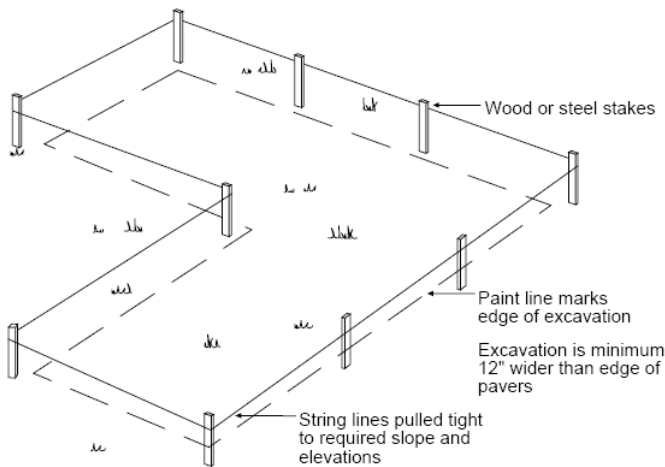

Job Layout and Staking

String lines set at final or finished elevations should be sloped. All lines (and final elevations of the pavement) should slope away from the house or building. **The minimum recommended slope is 1.5 percent or a drop of 3/16 in. for every foot of pavement. Many pavements are sloped at 2 percent or 1/4 in. per every foot of pavement as this will better facilitate drainage. The maximum slope for comfortable walking is 7 degrees or about 12 percent.** A builders level should be used to establish elevations using marks on stakes set around the area to be paved.

EXCAVATION/SUBGRADE BASE

- Base must be 12 in. wider than pavement on all sides.
- Use proper base material.
- Place and compact base in layers.
- Fully compact.

EDGE RESTRAINT

Edge restraints must be installed on that part of the pavement edge which is not restrained by an existing structure such as a building, concrete curb or concrete slab.

Edge restraints are typically placed before installing the bedding sand and pavers. Some edge restraints can be installed after placement of the pavers and before compaction. Troweled concrete edge restraint is installed after the pavers have been placed.

Be sure that any area where bedding or joint sand can escape through or under the edge restraint is lined with a strip of Geotextile. Loss of sand will cause eventual settlement of the pavers.

Back fill outside of edge restraint as soon as possible to prevent sand from escaping under the edge restraint.

SAND SETTING BED

Loose screed the washed concrete sand to an uniform thickness of 25 mm (1 in.) over the compacted base course. In no case should the sand be greater than 40 mm (1-1/2 in.) thick.

Do not compact the sand setting bed before laying pavers.

PAVERS

In most ICP projects, the pavers, regardless of paver shape, are laid in patterns where two sets of joints run perpendicular to each other. Radii or curves are cut into the pavement after the field pavers have been laid but not compacted. Straight joint lines not only make the finished pavement look clean and sharp but make installation much easier. If pavers shaped to geometrically interlock with each other are not laid in straight lines, they will not fit together.

To keep joint lines straight, parallel string lines or chalk lines snapped on the sand setting bed should be used. The lines should be spaced five to ten feet apart with the spacing equal to the laying modulus of the paver shape being installed. This can be determined by laying a course of pavers in the proper pattern with 3mm (1/8 in.) joints and measuring the distance between at the desired line separation distance.

Procedure:

- Snap a string line on the screeded sand in the center of the area(s) to be placed.
- The line should be perpendicular to the laying face.
- Place pavers in the given laying pattern on both sides of the line.
- If additional lines are snapped, they should be parallel to each other. Check this by measuring the distances at the opposite ends of each line. They should be equal.
- If they are not parallel, they can be erased and snapped again.

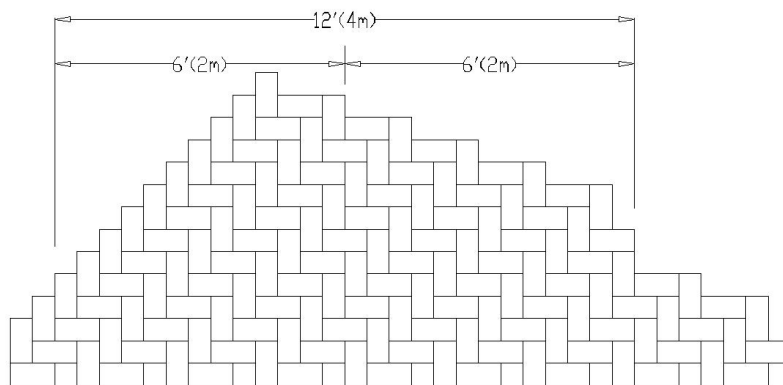

Parallel string lines are also used to pave around openings in the pavement such as manholes or swimming pools.

Procedure:

- Pull perpendicular string or snap chalk lines on all four sides of the opening.
- Lay pavers on one side, then the other.
- Count the courses needed to surround the openings on each side. They should be equal in number on both sides.
- Then fill around the remaining side of the opening.
- Cut pavers to fit and fill against the edge restraint around the opening.

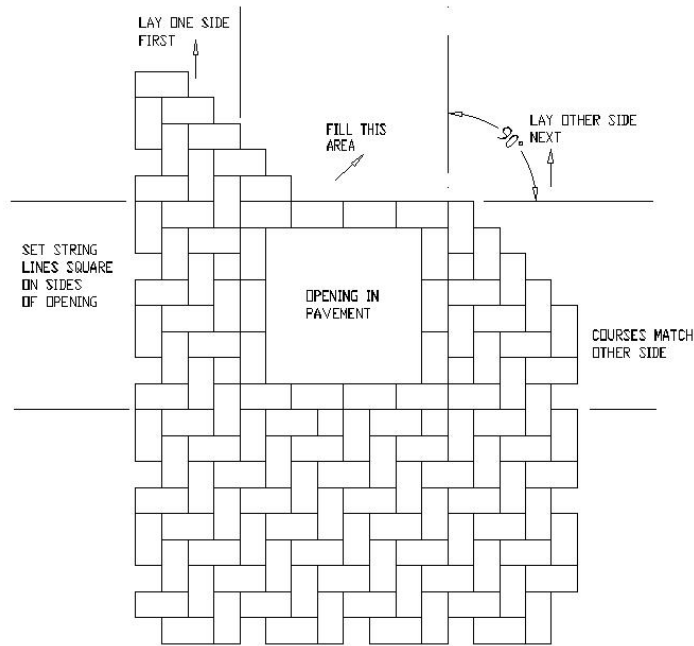

Plan your installation to begin along a straight line and preferably in a corner which is easily accessible. Make absolutely certain that the beginning corner is a true 90 degree angle. If the intersection of 2 sides is not a true 90 degree angle, you must establish a 90 degree starting point.

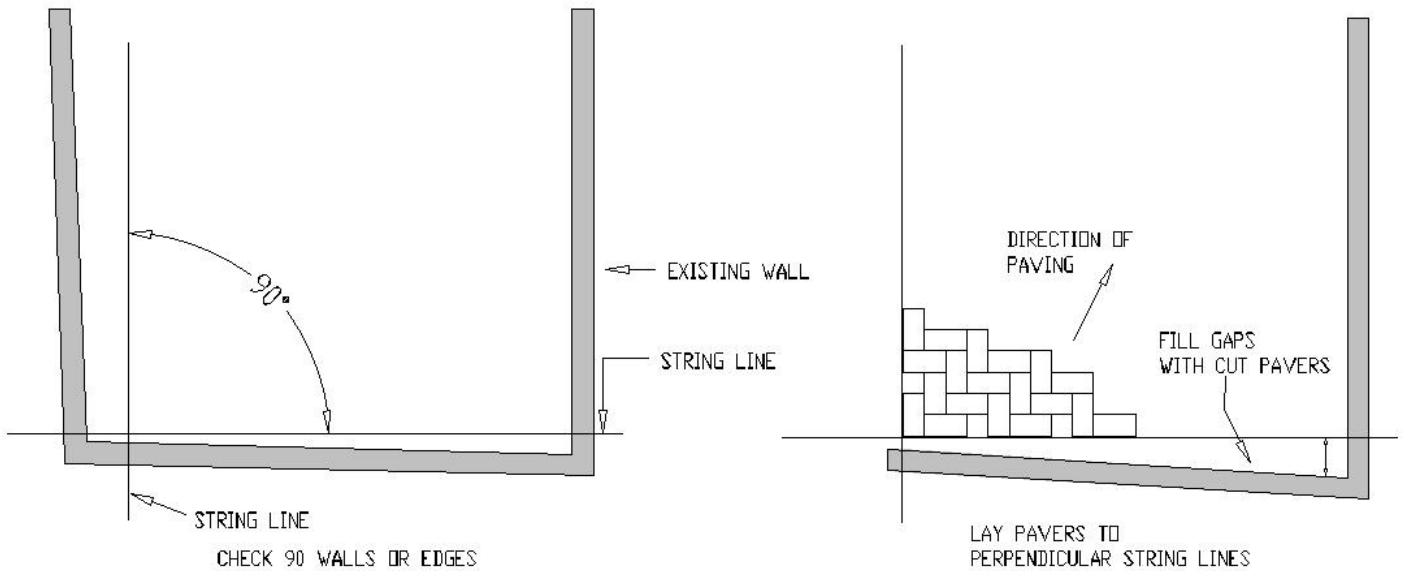

3:4:5 Triangle may be used to establish a 90 degree angle or to check existing corners:

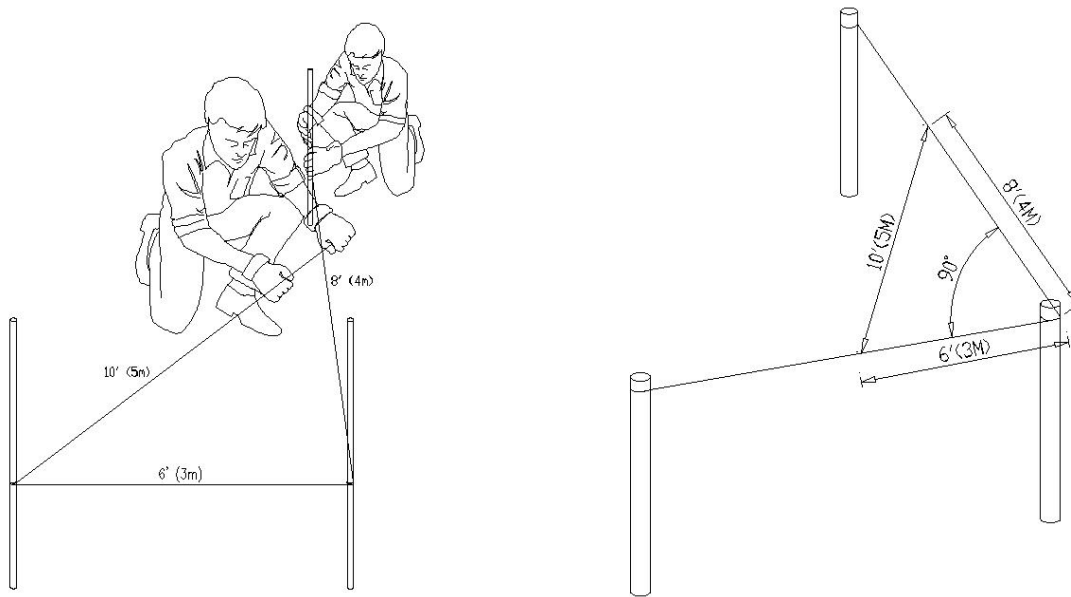

A quick way to establish a line perpendicular to an edge (no corner walls) is with the following procedure:

- Measure and mark the length of the edge, or line, from which paving will begin. The line can be 10-20 ft. (3-7m.) long. This line is where an edge restraint will be placed, or where one is already placed.
- Mark exactly the half way point on the line that was just measured. In other words, divide the line in half.
- Take one tape measure and extend it from the other end of the line at an angle toward the center.
- Be sure the tape extends past the middle of the line by a foot or two (0.2m.-0.6m.).
- Take a second tape measure and extend it from the other end of the line at an angle toward the center.
- Overlap one tape on the other and match the length of both tapes. The same marked dimensions on each tape should be touching each other.
- Snap a line from the point where the two tape measures cross to the center of the line.
- This line is perpendicular to the line from which paving will begin.

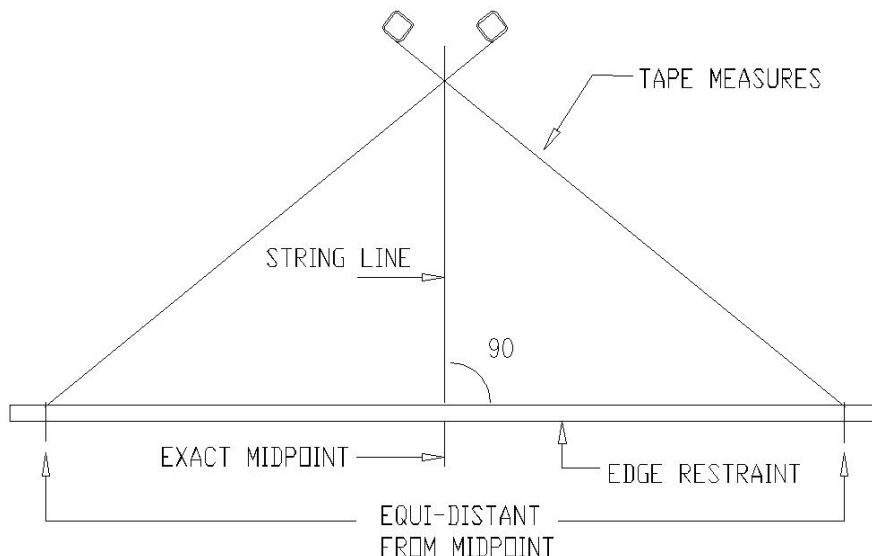

STARTING LAYING PATTERNS

Starting the first few rows of the pavement requires attention to the order of placing the pavers. The proper order for beginning herringbone patterns with a rectangular paver is illustrated below. The installation begins at a 90 degree corner.

When placing the pavers, it is important to maintain consistent joint spacing of 1/16 in. to 3/16 in. Consistent joint width of approximately 1/8 in. will spread loads (vertical interlock) better than wider joints. Consistent joint spacing will result in a neat and orderly appearance of the finished pavement.

The 1/16 in. spacer ribs molded into the sides of pavers are to ensure a minimal joint and that at least some sand can enter the joints between pavers. They are not intended to be the spacing mechanism.

The best way to maintain joint consistency during paving is by the “click and drop” method.

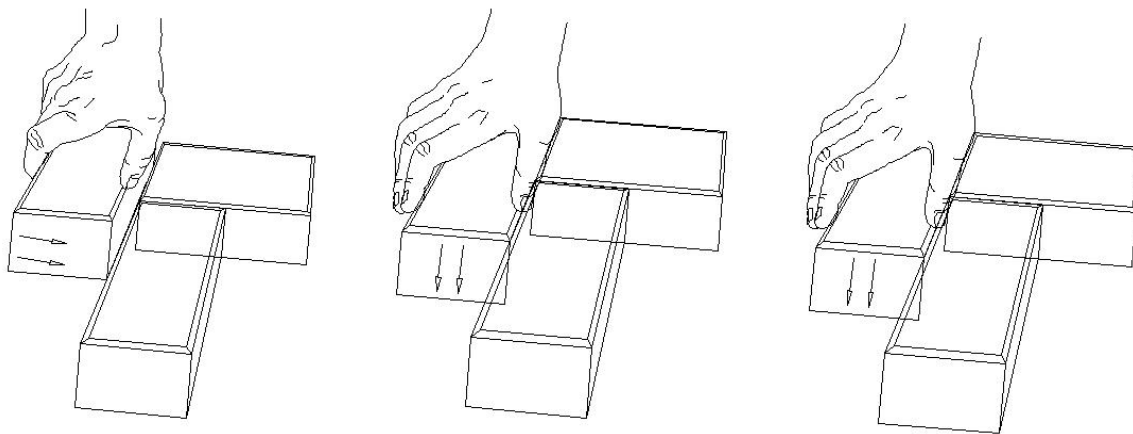

Click and Drop Procedure:

- While holding a paver, the bottom 1/4 in. to 1/2 in. should “click” firmly against the top portion of the side of the pavers already placed.
- Do not hit the previously placed pavers so hard that they move.
- Release grip, dropping the paver an inch or so directly downward. A slight pressure with fingers will ensure that the paver does not move away from those already placed.

CUTTING PAVERS

Pavers may be cut with any one of three basic pieces of equipment. They are:

1. Mechanical or guillotine splitter
2. Masonry saw
3. Hand held cut-off saw

Mechanical or guillotine cutters are relatively inexpensive to buy but produce the least desirable results. Masonry saws may be either gasoline engine or electric motor driven. They may be hand held or mounted on a stand. Hand held cut-off saws are the most convenient and produce the best overall combination of quality and productivity.

Edge Pavers and Paver Cutting

Especially manufactured edge units are available for some paver shapes. Check with your Authorized Belgard Dealer for availability of these units.

In most cases, pavers along the pavement edges will need to be cut. The four types of cutting equipment generally available are:

1. Mechanical cutter or guillotine splitter. This equipment cuts pavers between two steel blades through hydraulic or mechanical pressure. The cutting process is quick but the cut edge tends to be rough. The Equipment is relatively inexpensive.
2. Gasoline or electric powered saws mounted on a stand. These saws are generally set up to be run wet but can be run with a dry diamond blade. Very accurate cuts can be made but in most cases the pavers must be marked, brought to the saw, cut, then returned to the edge and installed. The process is labor intensive. Gasoline powered saws may be mounted on a coxet to facilitate the process.
3. Walk behind diamond saw. Powered in most cases by a gasoline engine, the units roll on wheels while cutting. They are usually set up to run wet but can use a dry diamond blade. The advantage is that the pavers may be cut in place. The quality of cut is excellent but the saws are awkward to maneuver.
4. Gasoline powered cut-off or quick saws. These hand held saws are similar to chain saws with the diamond saw blade replacing the chain. While some cut-off saws can be run wet, most are used with dry blades. These units provide good output and, in the hands of an experienced operator, excellent quality of cut. Cut-off saws have become the most used equipment for cutting pavers.

Tips

Diamond saw blades come in wet or dry versions. Dry blades may be run wet but wet blades should never be run dry. Use of water with either type blade extends blade life.

Care must be taken to make sure that the slurry (mixture of water and cutting dust) from wet saws or dust from dry saws is washed off installed pavers immediately before it dries. Surrounding structures, vegetation and automobiles should be protected from the dust. Cut-off saws with dust collection capability have recently become available.

Cutting Procedure

Mark lines to be cut with lumber pencil or crayon, chalk, welders soapstone or water-base liquid marker.

Do not use a marker which will not eventually come off. It is best to use a color which is easily visible against the color of the paver. Curved lines may be marked by using a garden hose as a guide.

The pavement will perform best if the size of cut units left in the pavement is as large as possible. Thin pieces tend to break or displace with time and use. In most cases, the pattern may be adjusted at or near the edge to allow for larger cut pieces. A border or header course of whole pavers between the field pavers and the edge restraint tends to keep the cut field pavers in place better than the edge restraint alone. The border pavers also add a neat finished appearance to the pavement.

Cut and place all edger pieces before compacting the pavers and applying joint sand.

Summary:

- Use proper hand, eye, ear and respiratory protection equipment.
- Mark lines to be cut.
- Maximize size of cut pieces to remain in pavement.
- Make clean neat cuts.
- Make all cuts before compacting pavement.
- Clean all cut residue from pavement immediately.
- Use paver border or header course as often as possible.

PAVEMENT COMPACTION AND JOINT SANDING

Compaction of the ICP evens the tops of the pavers and begins the process of vertical interlock by forcing some of the bedding into the joints from the bottom.

On small jobs, compaction should take place after all pavers, including cut edges, are in place. **On jobs lasting more than one day, all pavers placed should be compacted and the joints filled at the end of the workday.** Do not compact or fill joints within 3 ft. of any unrestrained or incomplete edge. Do not spread joint sand before initial compaction of pavement.

Using a gasoline powered vibratory plate compactor with a minimum compaction force of 5000 ft. lbs. for 3-1/8 in. pavers, follow this procedure:

Compacting Procedure

- Start on one edge of the pavement and compact the perimeter.
- Compact in overlapping rows on the rest of pavement.
- Compact the pavement again but in the opposite direction. **All pavers will need to be exposed to at least two passes of the compactor.**
- Do not compact within 3 ft. of an unrestrained edge or the pavers will creep out.
- The operator looks for broken pavers just behind the plate compactor and marks them while compacting. The broken pavers are removed with a paver extractor and replaced with whole units.

Figure 3 (bottom)

Compaction sequence working from the perimeter to the center of the pavement. All pavers should have two passes of the plate vibrator over them prior to filling the joints. After the joints are filled with sand, follow the same compaction sequence from the perimeter to the center.

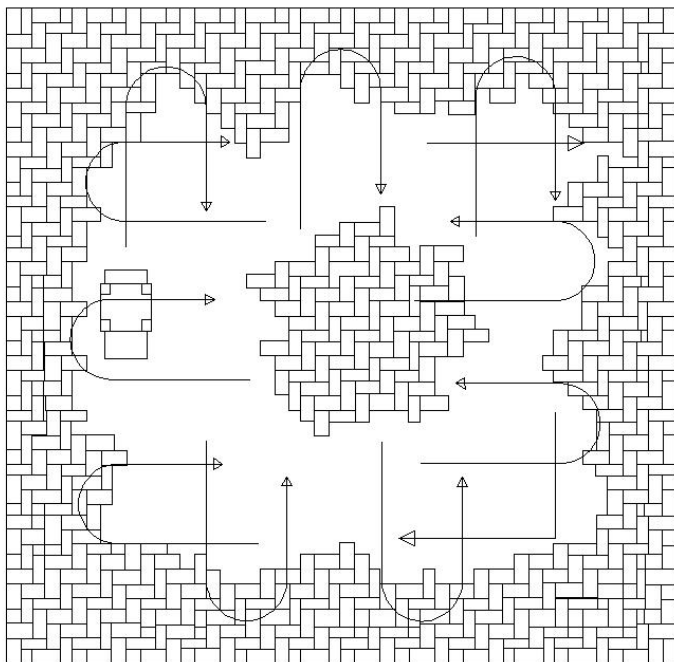

JOINT SANDING

After compaction of pavement and replacement and recompaction of replacement pavers, spread the joint sand. Dry sand works best, so if the sand is damp, allow it to dry. Sweep the dry sand into the joints. If necessary, dry

bagged sand conforming to ASTM C144 may be used. Do not use mason sand, play sand or sandbox sand. After the initial sweeping, the filling of the joints can be expedited by alternating sweeping and passes of the vibratory plate compactor. Continue until all joints are filled. **It is a good idea to reinspect a job two to three weeks after completion at which time it may be necessary to re-sweep sand into the joints.**

Summary:

- Compact pavement after pavers are installed and before joint sand is spread.
- Replace broken pavers while compacting and before applying joint sand.
- Spread and dry joint sand.
- Sweep joint sand into joints and fill by alternating sweeping and vibrating.
- Check job in 2-3 weeks and re-sand if necessary.
- Sweep off excess sand. On some commercial jobs, excess sand may be left on the pavement to help ensure joints are filled.

COMPLETION OF PROJECT

When the installation has been completed, clean up the site. Some pavers of each shape and color used may be left with owner for possible future replacement. Store these pavers neatly where the owner directs. Walk the job with the owner and address any problems immediately. Review maintenance procedures with the owner and leave information regarding care and maintenance with him/her.