

**Specifications for Concrete Cobble Square 80mm thick Shotblasted finish with Premier Shield protection (Integral and top coat treatment)**

Supply of Solid Concrete Cobbles of VYARA make, in Shotblasted and coated finish

- in colours specified by the architects.
- using UV resistant color pigments from Lanxess.
- wear resistant color coordinated aggregates.
- Premier Shield integral and topcoat treatment for satin finish, water and oil repellence, reduction of algae, moss and efflorescence formation.
- Size 97\*97\*80 mm thick. Nominal size of 100mm \*100mm.

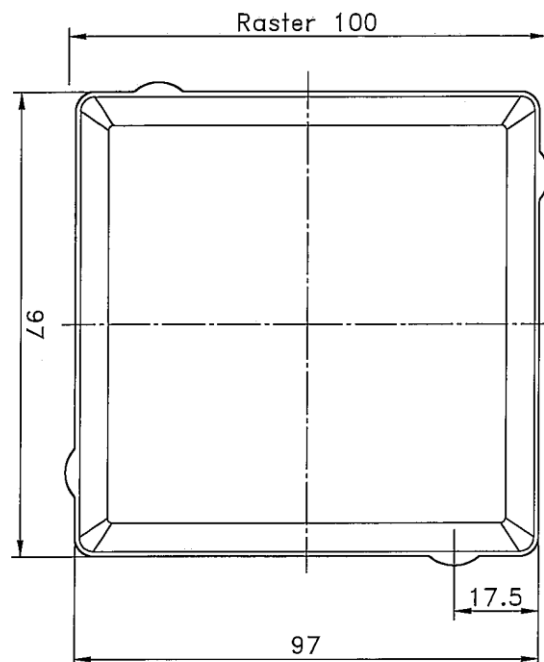

Sr.	Parameters	Minimum Requirements
1.	Percentage Water Absorption	Average not over 6%
2.	Compressive strength	Average not less than 300 Kg/cm <sup>2</sup>
3.	Tensile Splitting Strength (as per EN 1338)	Average not less than 3.6Mpa
4.	Average wear in Thickness-Abrasion	Conforming to Grade 'H' of EN 1338
5.	Tolerance in size (length + breadth)	±1.5mm
6.	Thickness of wearing layer	Not less than 5mm
7.	Tolerance in Thickness of block	±3mm
8.	Colours	UV Light resistant fast colours from Lanxess only to be used

- The Concrete Cobbles must be manufactured on Vibropress type machine only. The manufacturer must demonstrate the feeding of material into the machines by automatic batching plants with capacity of min 30 m<sup>3</sup>/hr.
- The manufacturing company must be an ISO 9001:2015 certified Company or should have equivalent quality management systems in place to ensure quality product.
- The Concrete Cobbles must meet the sustainability criteria and should be certified as a green product by CII.
- The Concrete Cobbles will be made using wear resistant materials in the face mix as specified by the architects.
- The colours of the Concrete Cobbles (wearing layer) will be as selected by the architects.
- The Concrete Cobbles must be cured in a controlled environment to ensure efflorescence free material.
- The manufacturer must have in house testing laboratory to carry out all testing including Compressive strength testing, Water absorption, abrasion resistance etc.